

Main Amplifier Circuit

	A	B	C	D
	1	2	3	4
	5	6	7	8
	9	10	11	12
	13	14	15	16
IC101,201	8.36	7.68	8.51	8.46
	6.02	5.19	1.04	4.72
	9.19	9.17	0.35	0
	0.08	0.71	18.75	9.21
				10

	1	2
IC1	11.26	11.29
IC2	11.4	11.35
IC51	PLAY	STOP
	L	L
IC52	REW	FF,PLAY or PAUS
	L	L

1
2
3
4
5
6
7

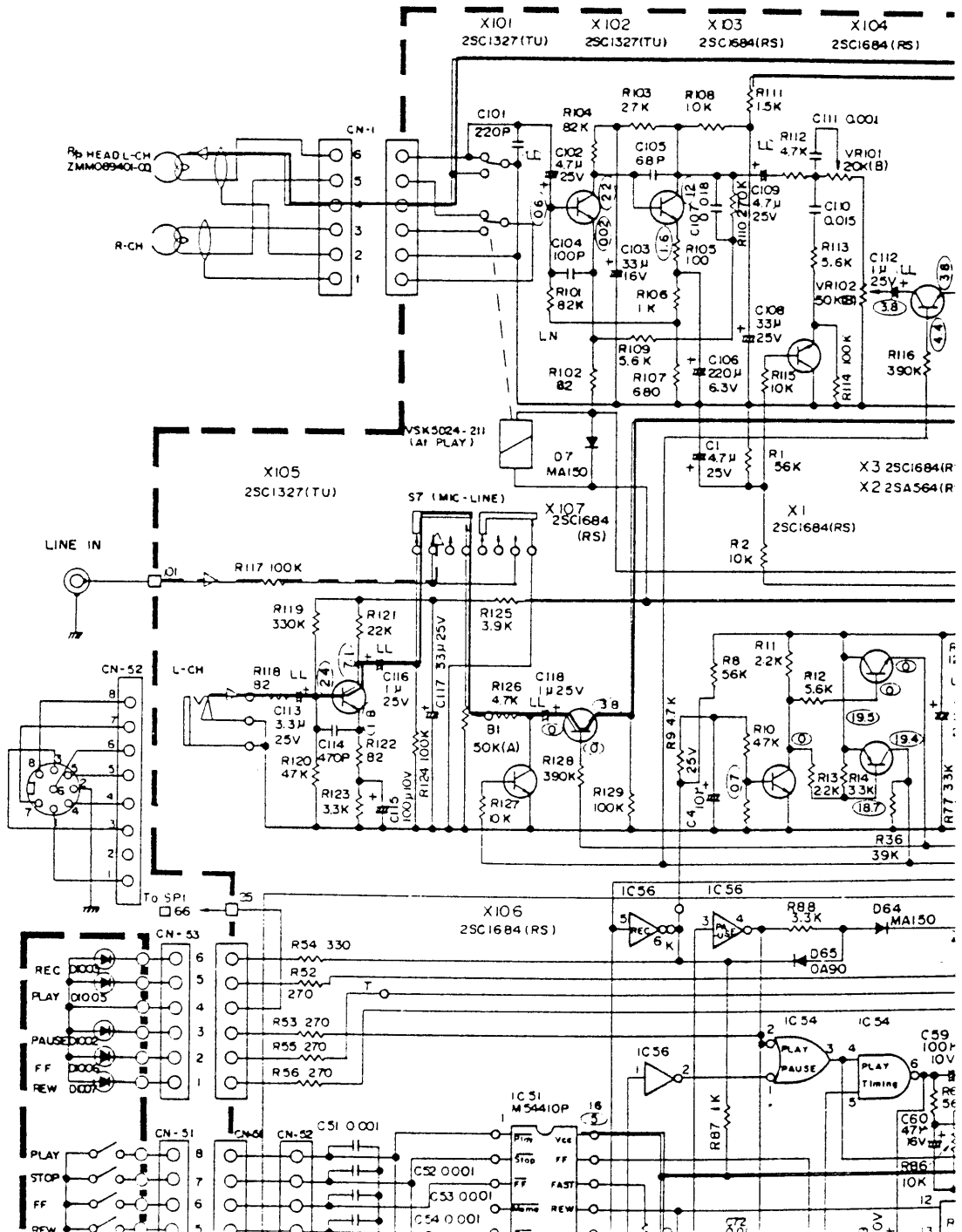

C D E F G

5	6	7	8	9	10	11	12	13	14	15	16	17	18	19	20	21	22	23	24
6.02	5.19	1.04	4.72	9.19	9.17	0.35	0	0.06	0.71	18.75	9.21	10.52	9.24	10.55	11.79	11.8	11.81	11.8	16.5

	1	2	3	4	5	6	7	8	9	10	11	12
IC1	11.26	11.29	11.26	0	11.26	11.27	11.29	22.6				
IC2	11.4	11.35	10.9	0	10.8	11.3	11.51	22.6				
IC51	PLAY	STOP	FF		REW	PAUSE	REC		REC	REC	PAUSE	PLAY
	L	L	L	H	L	L	L	0	L	H	H	H
IC52	REW	FF, PLAY	FF, REW	PLAY or	PLAY or	PLAY or						
	L	L	PLAY or	PAUSE	PAUSE	PAUSE						
			PAUSE	H	H	H	0	—	—	—	—	—

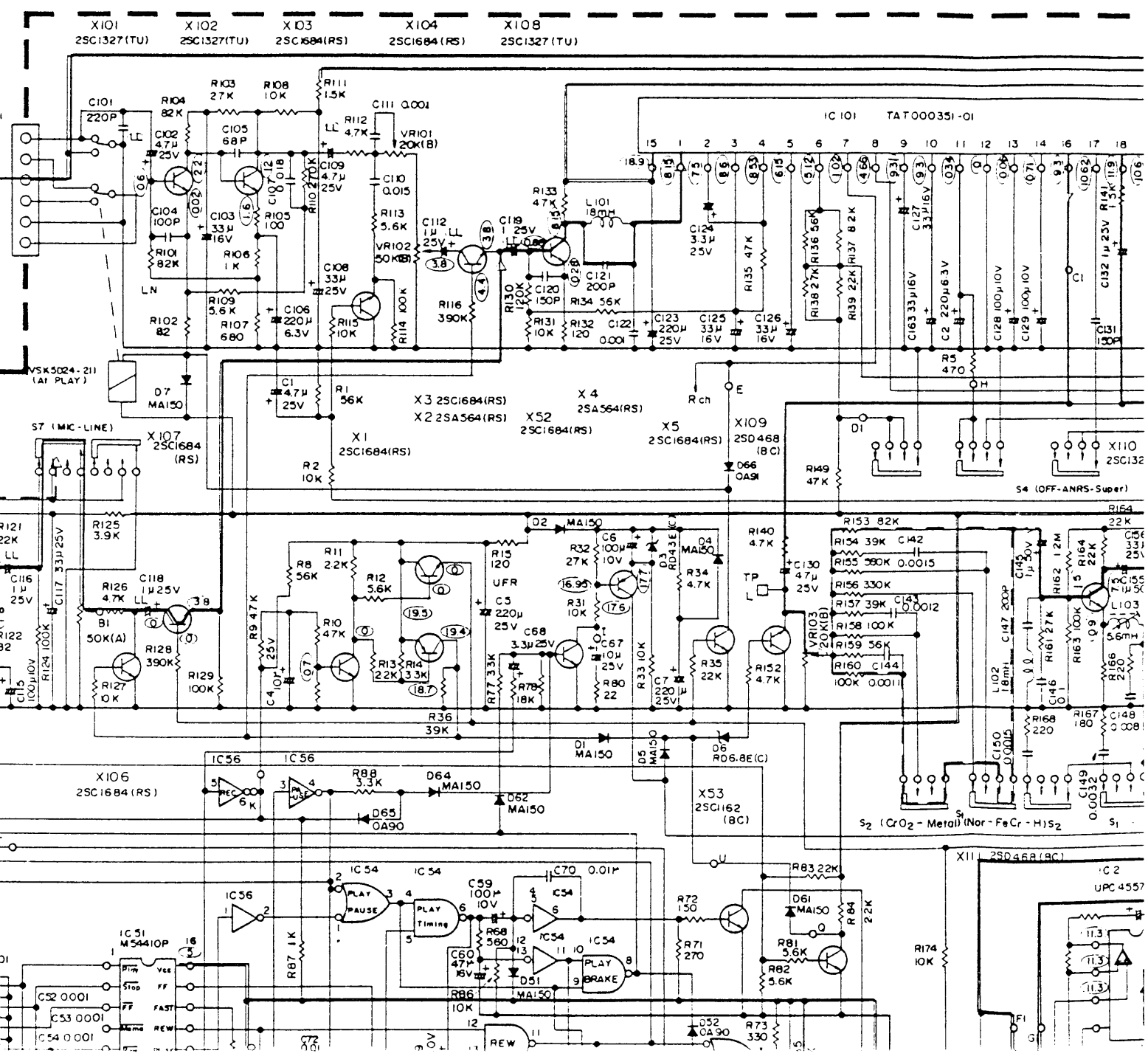

F G H I J K

22	23	24
11.81	11.8	16.5

5	6	7	8	9	10	11	12	13	14	15	16
26	11.27	11.29	22.6								
9.8	11.3	11.51	22.6								
REW	PAUSE	REC		REC PROOF ON	REC	PAUSE	PLAY	REW	FF or REW	FF	
L	L	L	O	L	H	H	H	H	H	H	5V
Y or USE	PLAY or PAUSE										
		0	—	—	—	—	—	—	—	—	

	1	2	3	4
IC53	POWER ON			
IC54	PLAY	PAUSE	PLAY or PAUSE	PLAY or PAUSE
	L	L	H	H
IC55	PLAY or PAUSE	TAPE END	PLAY TAPE END	TAPE END
	H	H	L	H
IC56	PLAY	PLAY	PAUSE	PAUSE
	H	L	H	L

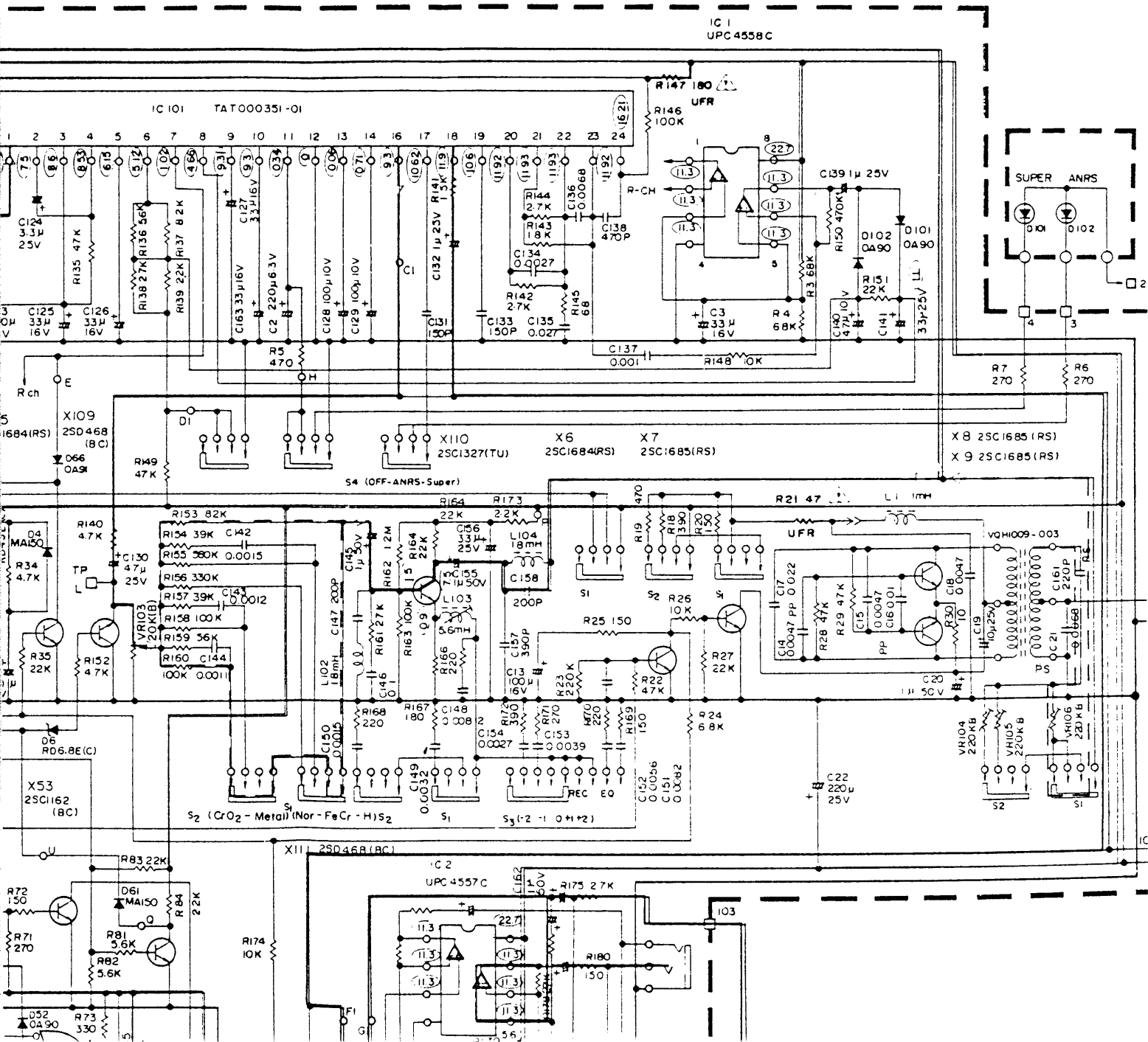

KD-A7A/B/C/E/J/U

J

K

L

M

N

	1	2	3	4	5	6	7	8	9	10	11	12	13	14
IC53	POWER ON						0	999_REW	REW	999_REW		999		5V
IC54	PLAY	PAUSE	PLAY or PAUSE	PLAY or PAUSE	FF or REW	PLAY or PAUSE	0	PLAY or PAUSE						5V
	L	L	H	H	L	L		L	H	H	H	L	L	
IC55	PLAY or PAUSE	TAPE END	PLAY TAPE END	TAPE END	FF or REW	FF or REW TAPE END	0	FF	FF	FF or REW	REW	REW	FF or REW	5V
	H	H	L	H	H	L		L	H	H	L	H	H	
IC56	PLAY	PLAY	PAUSE	PAUSE	REC	REC	0	FF or REW			PAUSE			5V
	H	L	H	L	H	L		H	L	L	H	H	L	

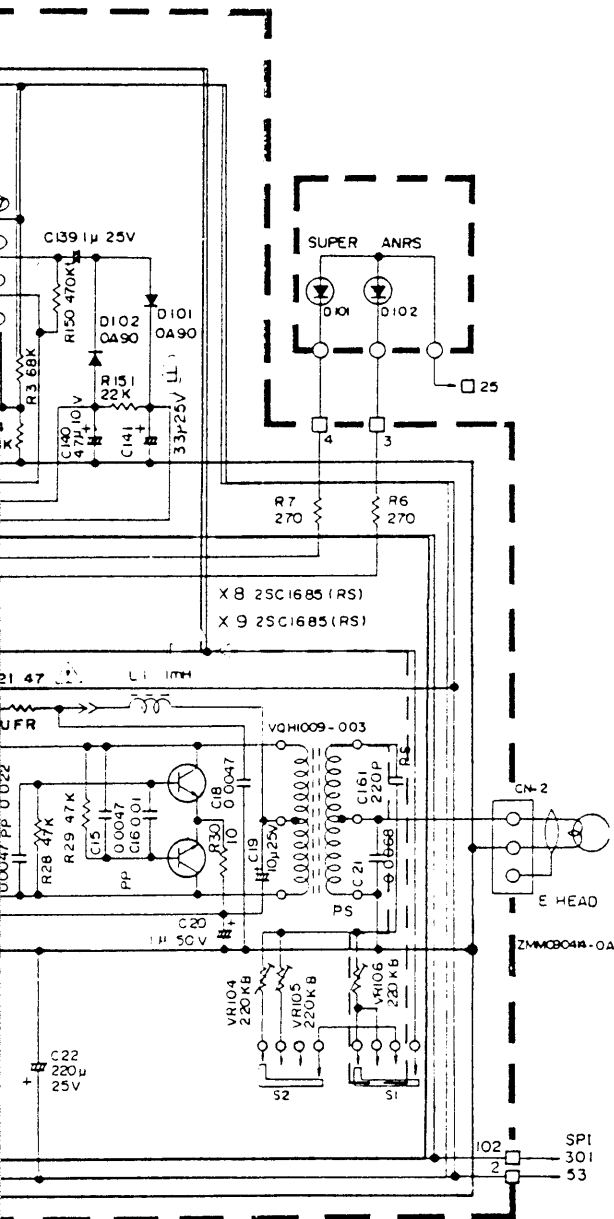

	E	C	B
X101,201	0.01	2.1	0.6
X102,202	1.5	11.8	2.1
X103,203	—	—	NORM Other 0.6
X104,204	3.8	Except REC 3.8	Except REC 4.4
X105,205	1.87	823	2.45
X106,206	—	—	REC Other 0.6
X107,207	3.8	REC 3.8	REC 4.4
X108,208	0.27	8	0.87
X109,209	0	0	REC or REC MUTE 0.6
X110,210	0.95	7.5	1.5
X111,211	0	—	PLAY or REC Other 0.6 0
X1	0	REC Other 19.8 0.1	REC Other 0.2 0.7
X2	20.2	REC Other 19.3	REC Other 20 18.6
X3	REC Other 19 0	20	REC Other 19.6 0
X4	18.3	PLAY or REC Other 18.3	PLAY or REC Other 17.7 21.9
X5	0	REC Other 1.04	REC Other 0.6 0
X6	0	REC Other 11	REC MUTE Other 0.6 0
X7	0	REC Other 22	REC Other 0.6 0
X9	REC Other 0.07 22.1	REC Other 19.9 22.5	REC Other 1.2 22.4
X51	0	TAPE END H	0.6
X52	0	PLAY or REC H	PLAY or REC 0
X53	0	PLAY or PAUSE 	PLAY or PAUSE
X54	0	PAUSE Other L	PAUSE Other H 0.6 0
X55	0	PAUSE	PAUSE 0.6
X56	0	REC MUTE Other 20 0	REC MUTE Other 0 0.6

- Diode -

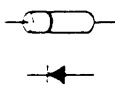

- Transistor -

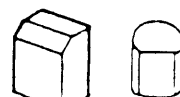

3
4
5
6
7
8
9
10

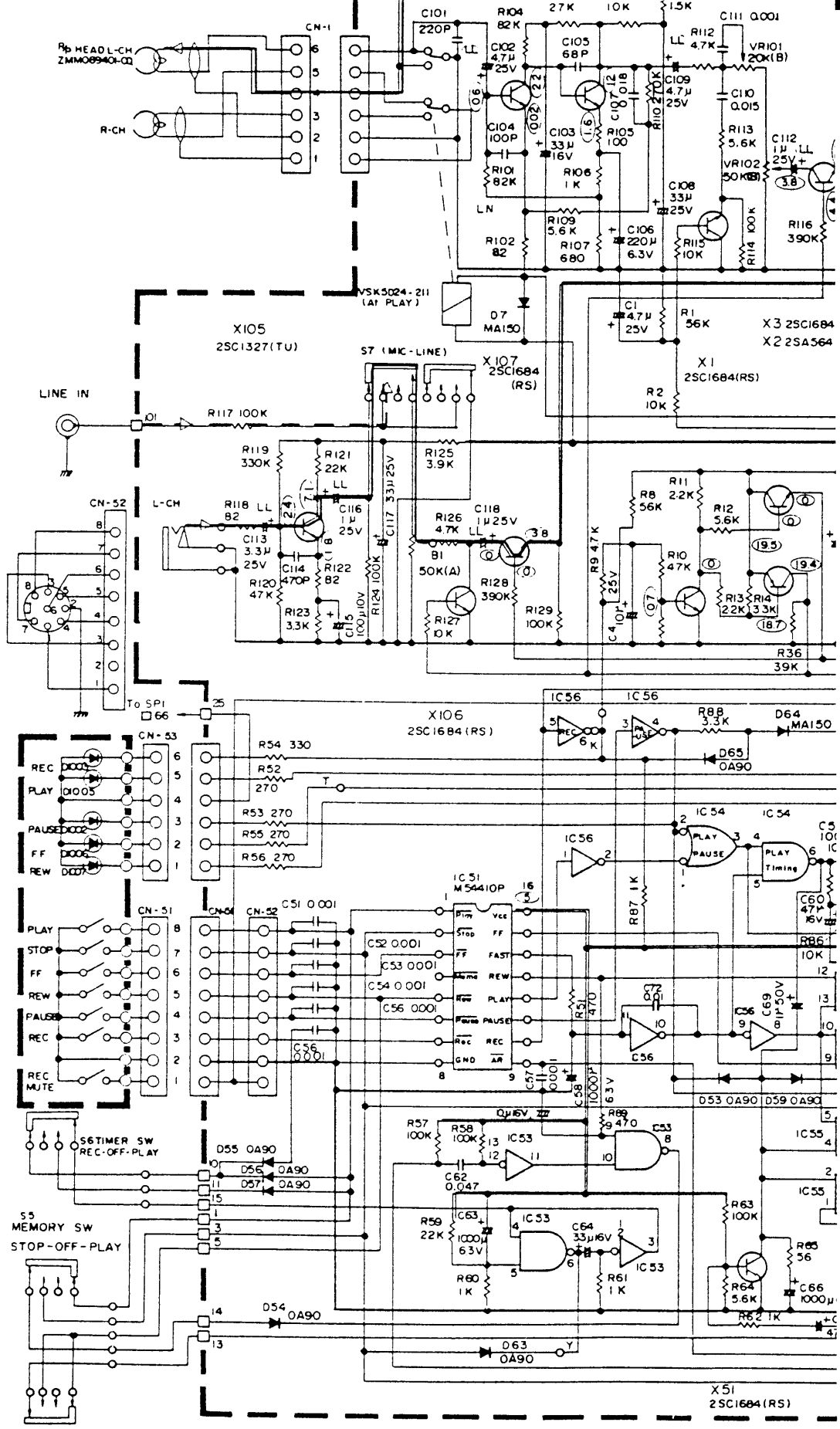

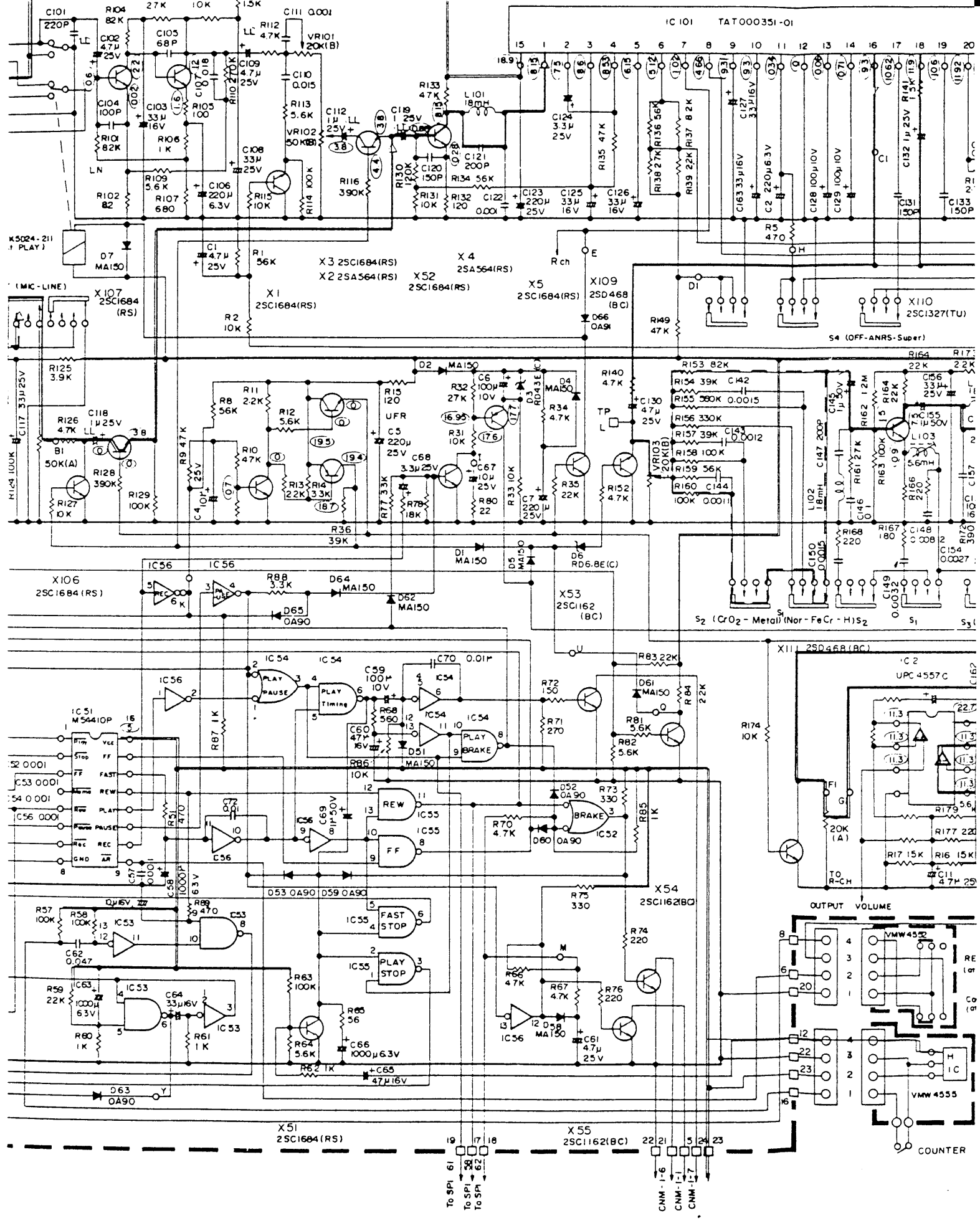

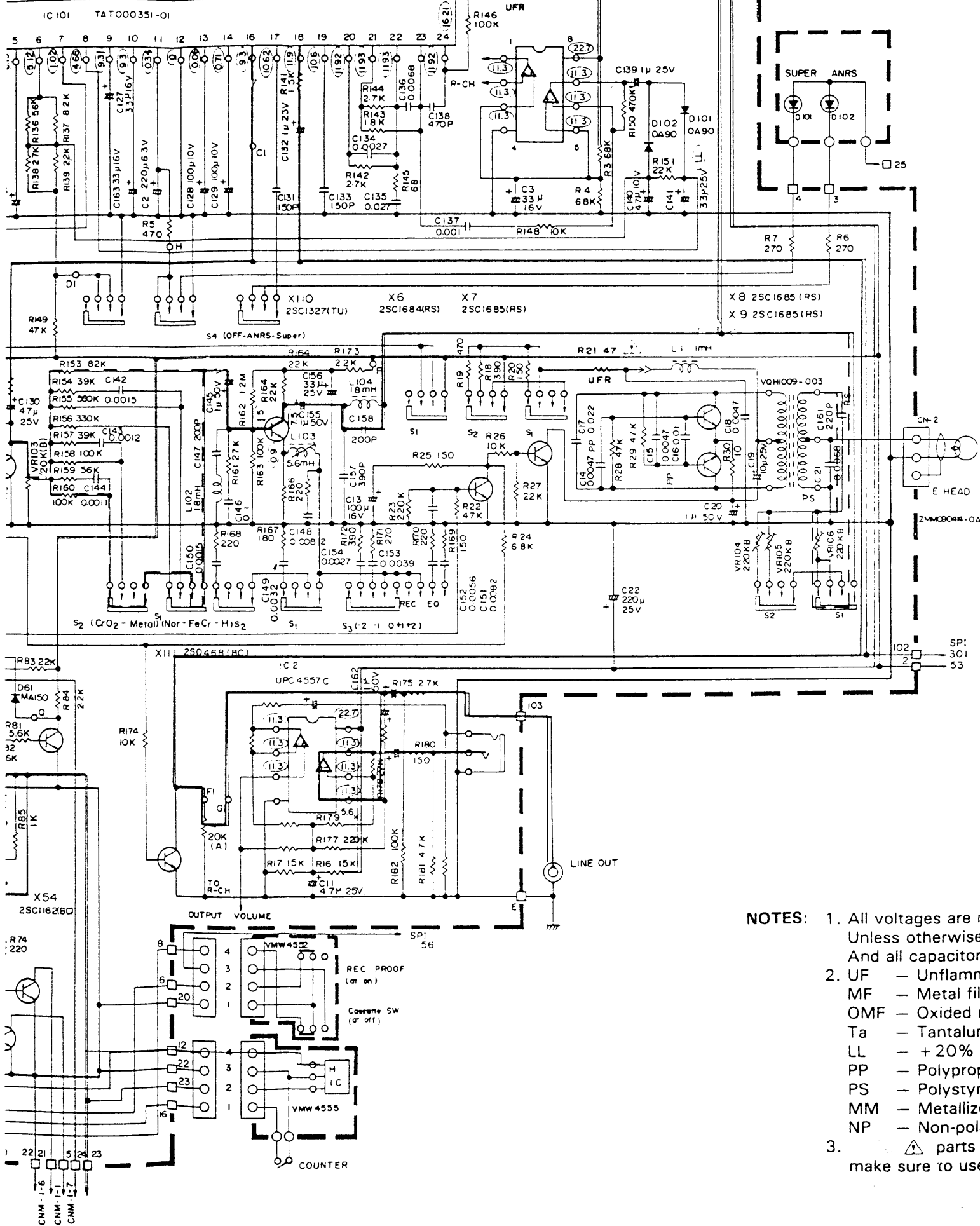

- NOTES:**
1. All voltages are m...
Unless otherwise :
And all capacitors
 2. UF - Unflamma...
MF - Metal film...
OMF - Oxided m...
Ta - Tantalum...
LL - + 20% lo...
PP - Polystyre...
PS - Polystyre...
MM - Metallized...
NP - Non-polar...
 3. parts ar...
make sure to use

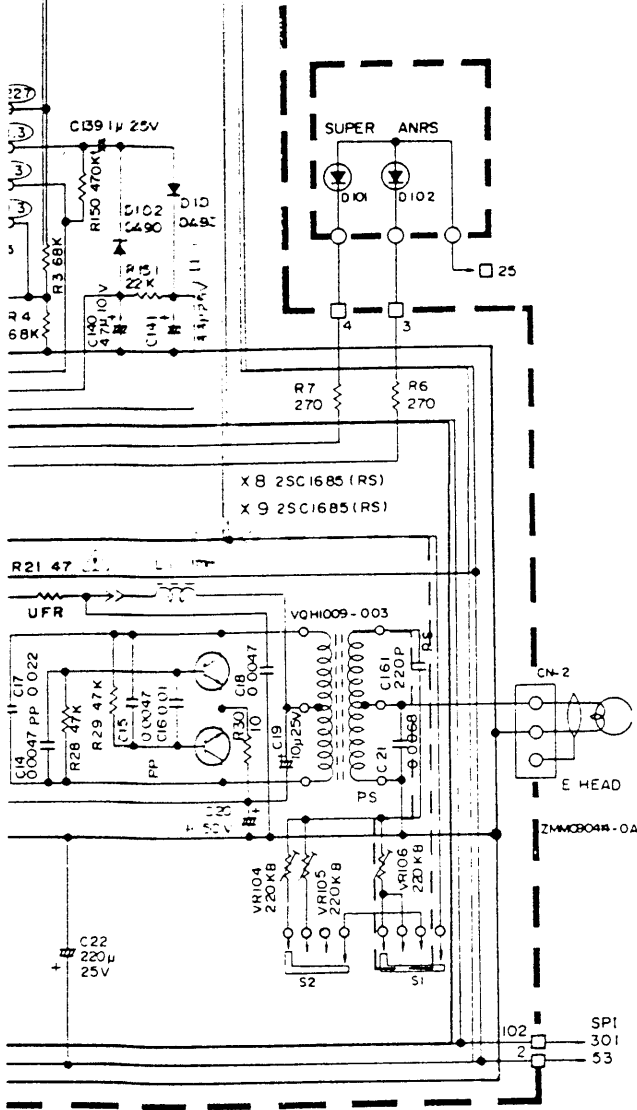

X103,203				NORM Other	0 0.6	
X104,204	3.8		Except REC 3.8	Except REC 4.4		
X105,205	1.87		823	2.45		
X106,206				REC Other	0 0.6	
X107,207	3.8	REC	3.8	REC	4.4	
X108,208	0.27		8	0.87		
X109,209	0		0	REC or REC MUTE	0.6	
X110,210	0.95		7.5	1.5		
X111,211	0			PLAY or REC Other	0.6 0	
X1	0	REC Other	19.8 0.1	REC Other	0.2 0.7	
X2	20.2	REC Other	0 19.3	REC Other	20 18.6	
X3	REC Other	19 0	20	REC Other	19.6 0	
X4	18.3	PLAY or REC Other	0 18.3	PLAY or REC Other	17.7 21.9	
X5	0	REC Other	0 1.04	REC Other	0.6 0	
X6	0	REC Other	11 0	REC MUTE Other	0.6 0	
X7	0	REC Other	0 22	REC Other	0.6 0	
X9	REC Other	0.07 22.1	REC Other	19.9 22.5	REC Other	1.2 22.4
X51	0		TAPE END H		0.6	
X52	0		PLAY or REC H		PLAY or REC 0	
X53	0		PLAY or PAUSE 		PLAY or PAUSE 	
X54	0	PAUSE Other	L H	PAUSE Other	0.6 0	
X55	0	PAUSE	0	PAUSE	0.6	
X56	0	REC MUTE Other	20 0	REC MUTE Other	0 0.6	

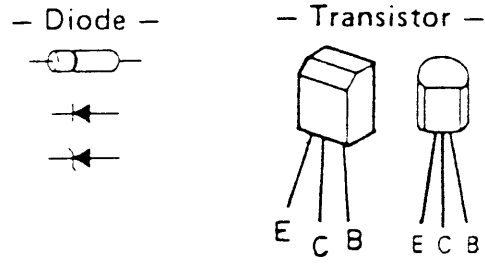

LINE OUT

- NOTES:**
- All voltages are measured by Electronic Voltmeter. Unless otherwise specified, all resistors are 1/4W, ± 5% carbon resistors. And all capacitors are 50V fixed ceramic capacitors or 50V mylar capacitors.
 - UF - Unflammable carbon resistor
 - MF - Metal film resistor
 - OMF - Oxided metal film resistor
 - Ta - Tantalum solid electrolytic capacitor
 - LL - + 20% low leak current electrolytic capacitor
 - PP - Polypropylene capacitor
 - PS - Polystyrene capacitor
 - MM - Metallized mylar capacitor
 - NP - Non-polarized electrolytic capacitor
 - ⚠ parts are safety assurance parts. When replacing those parts, make sure to use the specified one.

Spectro-peak Level Circuit

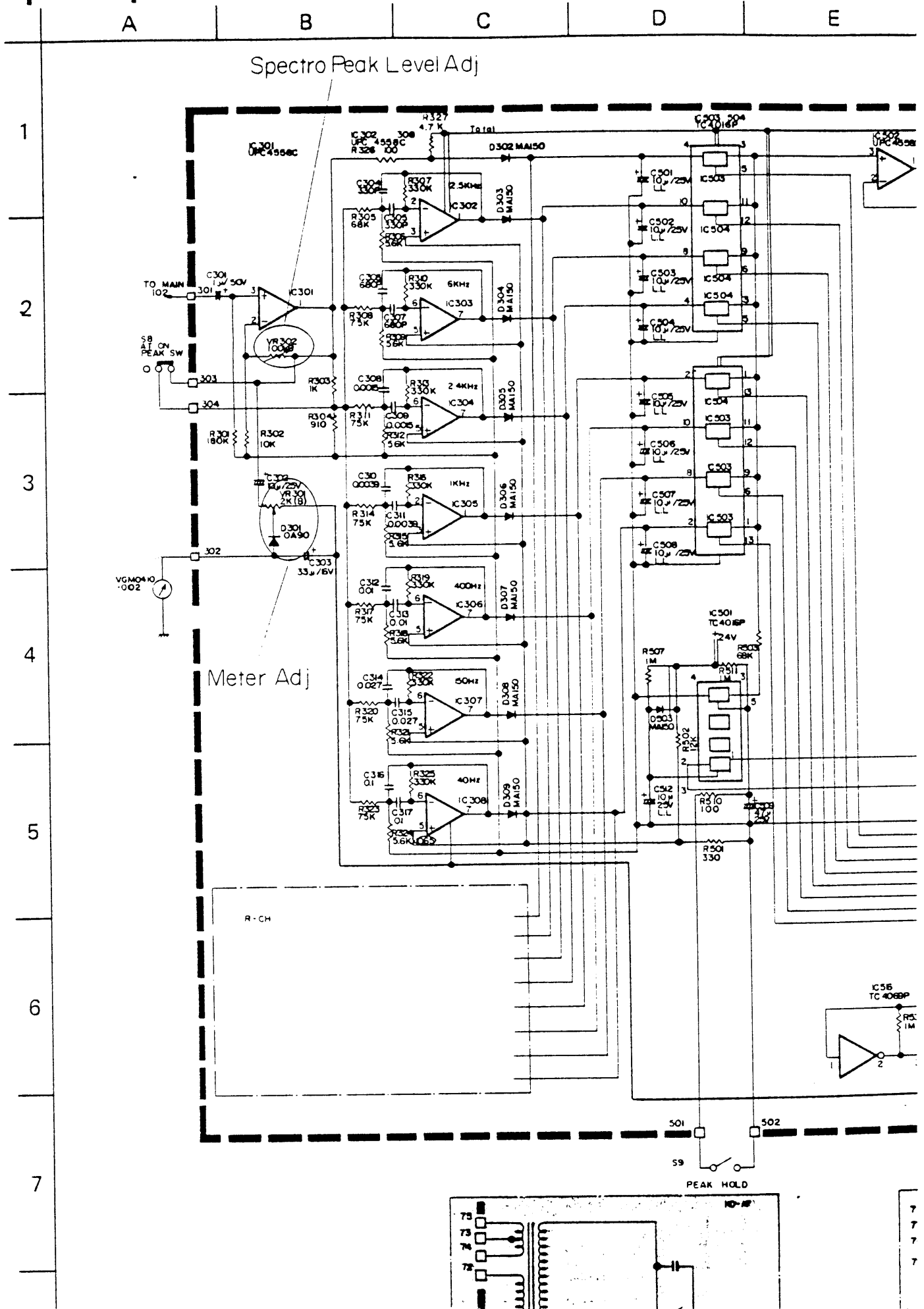

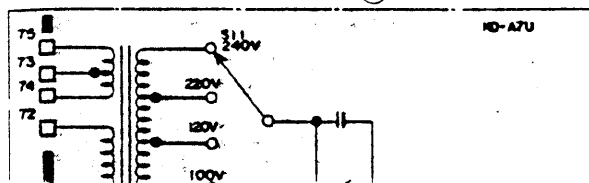
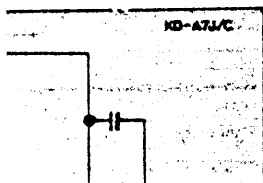
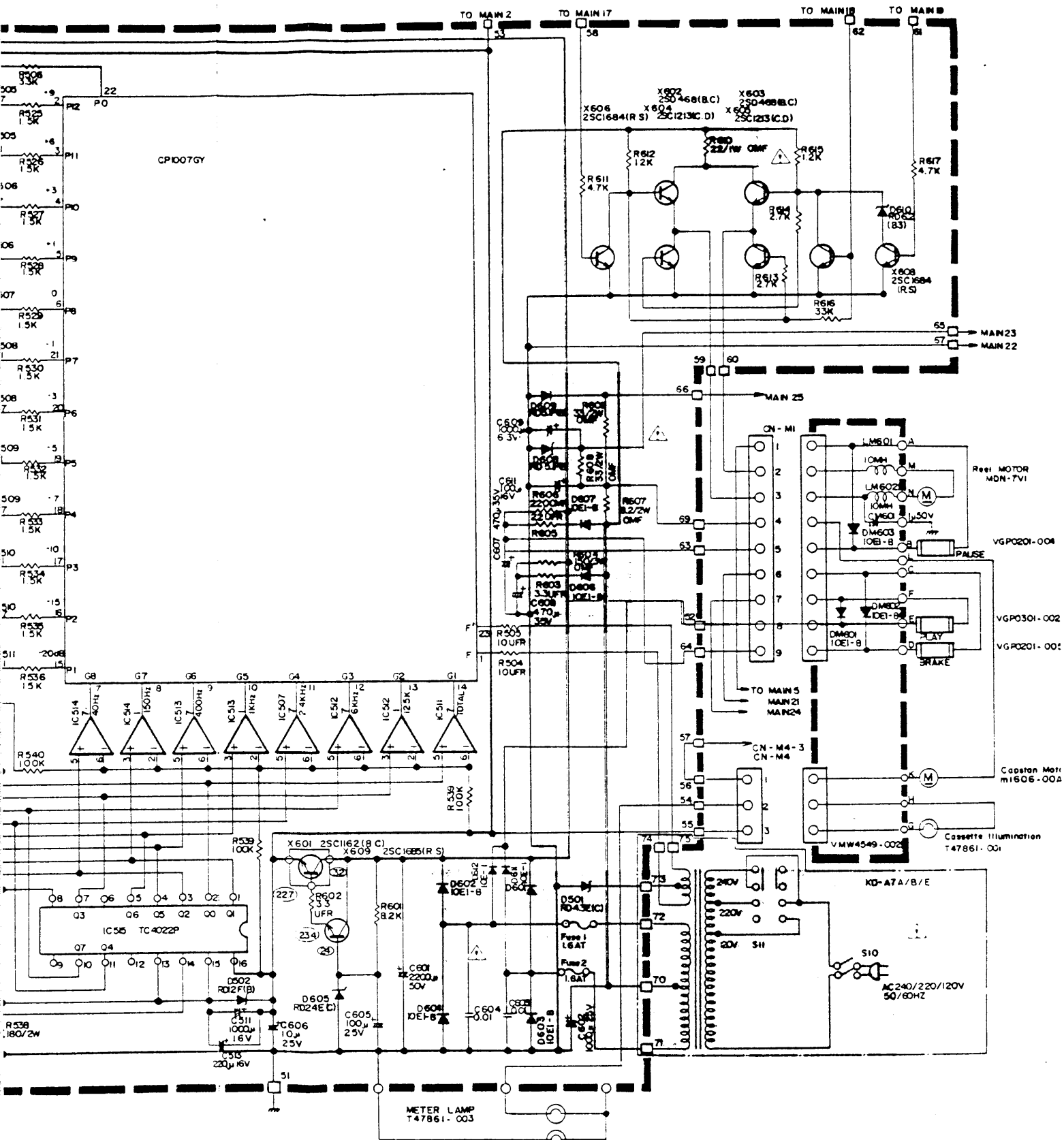

K

L

M

N

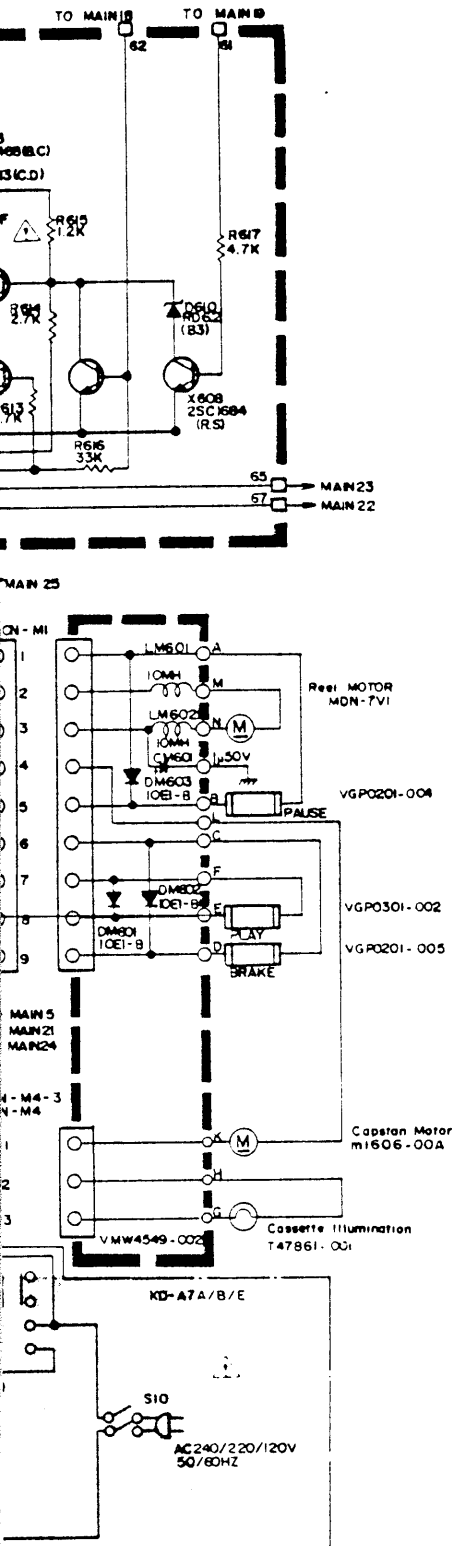

	E	C	B
X601	22.7	32.0	23.3
X602	STOP & REW 0 PLAY 5.8 FF 8.7	12.8	STOP & REW 0 PLAY 6.4 FF 9.3
X603	FF 8.6 PLAY & PAUSE 5.6 Other 0	12.0	FF 9.2 PLAY & PAUSE 6.3 Other 0
X604	0	REW 8.5 Other 0	FF, PLAY 0.7 Other 0
X605	0	FF 8.6 PLAY or PAUSE 5.6 Other 0	REW 0.75 Other 0
X606	0	0	0
X607	0	FF 9.2 PLAY 6.3 Other 0	REW, STOP or PAUSE 0.7 Other 0
X608	0	FF 4.5 Other 0	PLAY or PAUSE 0.6 Other 0
X609	23.4	32.0	24.0

3
4
5
6
7
8
9
10

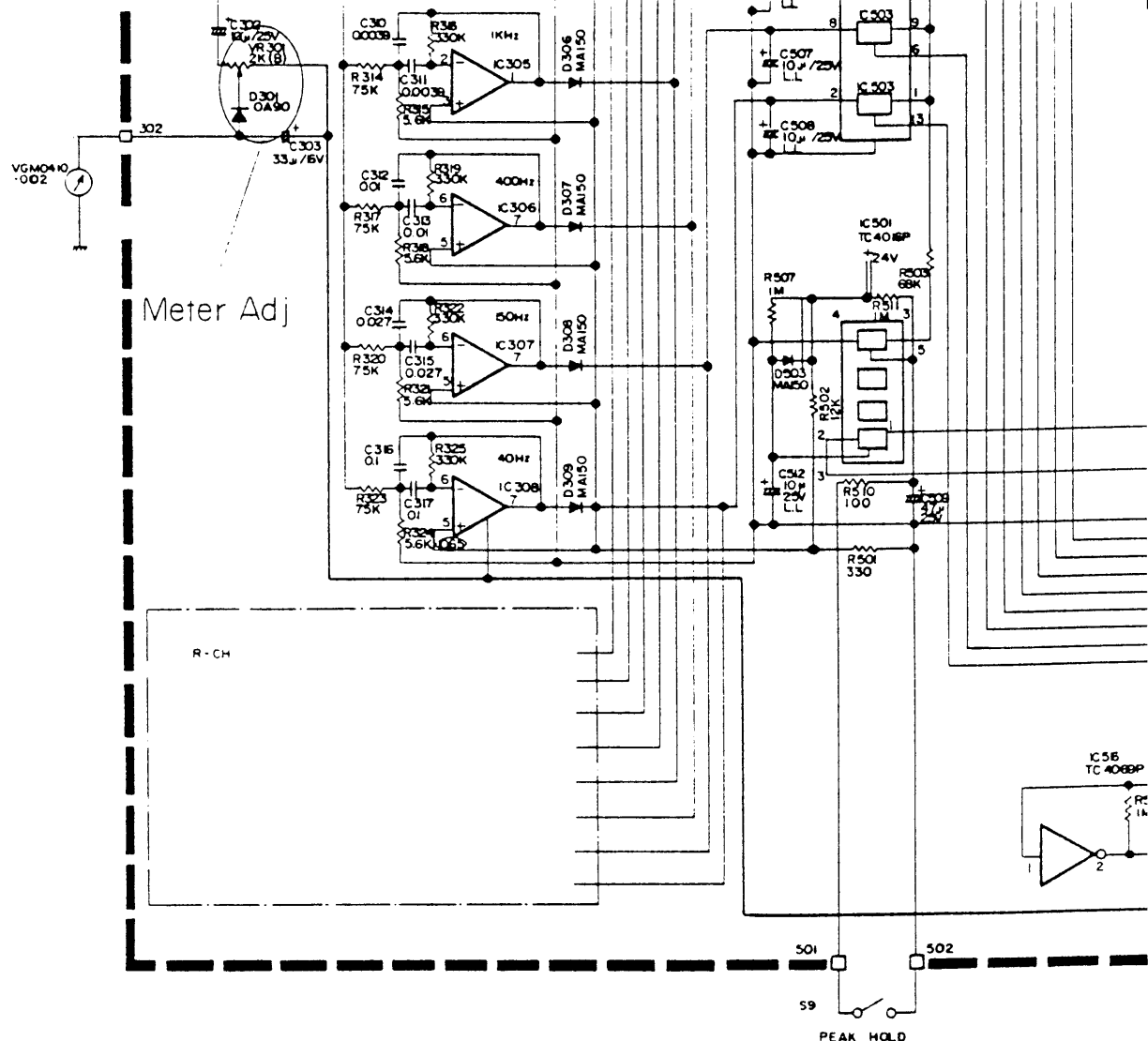

Meter Adj

R-CH

PEAK HOLD

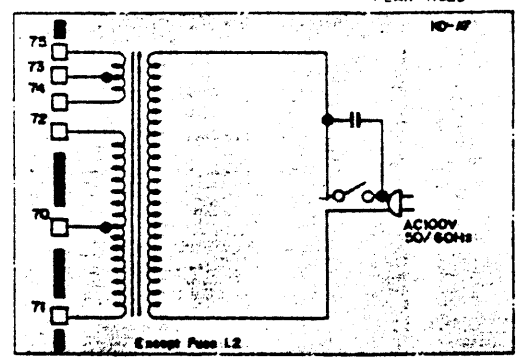

NOTES:

- All voltages are measured by Electronic Voltmeter.
Unless otherwise specified, all resistors are 1/4W, ± 5% carbon resistors
And all capacitors are 50V fixed ceramic capacitors or 50V mylar capacitors
- UF - Unflamable carbon resistor
MF - Metal film resistor
OMF - Oxided metal film resistor
Ta - Tantalum solid electrolytic capacitor
LL - + 20% low leak current electrolytic capacitor
- △ parts are safety assurance parts. When replacing those parts,

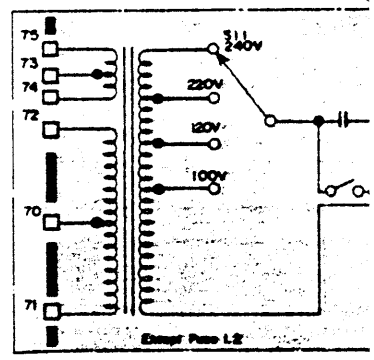
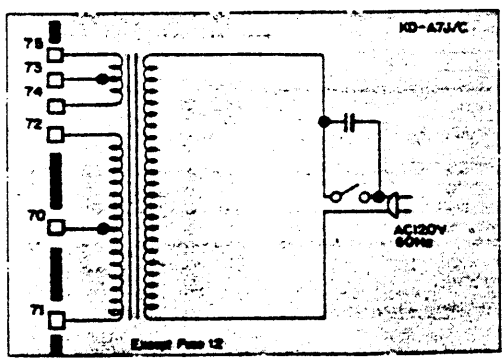
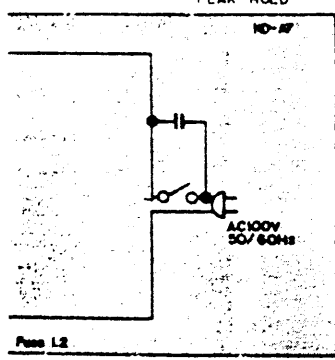
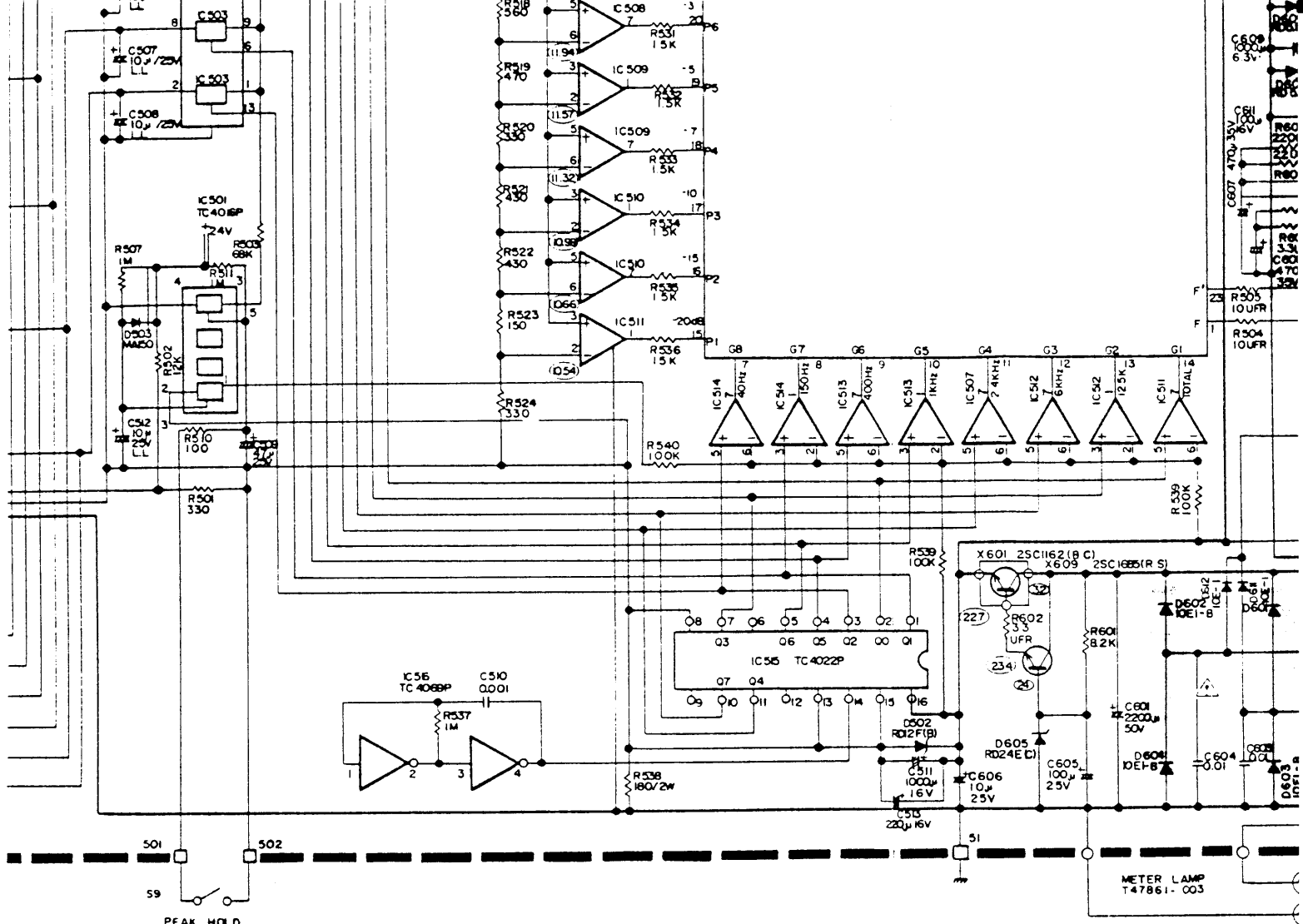

Electronic Voltmeter.
 All resistors are 1/4W, ± 5% carbon resistors.
 Fixed ceramic capacitors or 50V mylar capacitors.
 Variable capacitor
 Electrolytic capacitor
 Non-polarized electrolytic capacitor
 Assurance parts. When replacing those parts, make sure to use the specified one.

PP — Polypropylene capacitor
 PS — Polystyrene capacitor
 MM — Metallized mylar capacitor
 NP — Non-polarized electrolytic capacitor

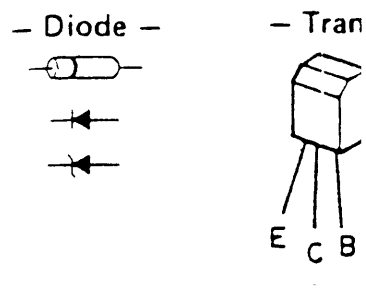

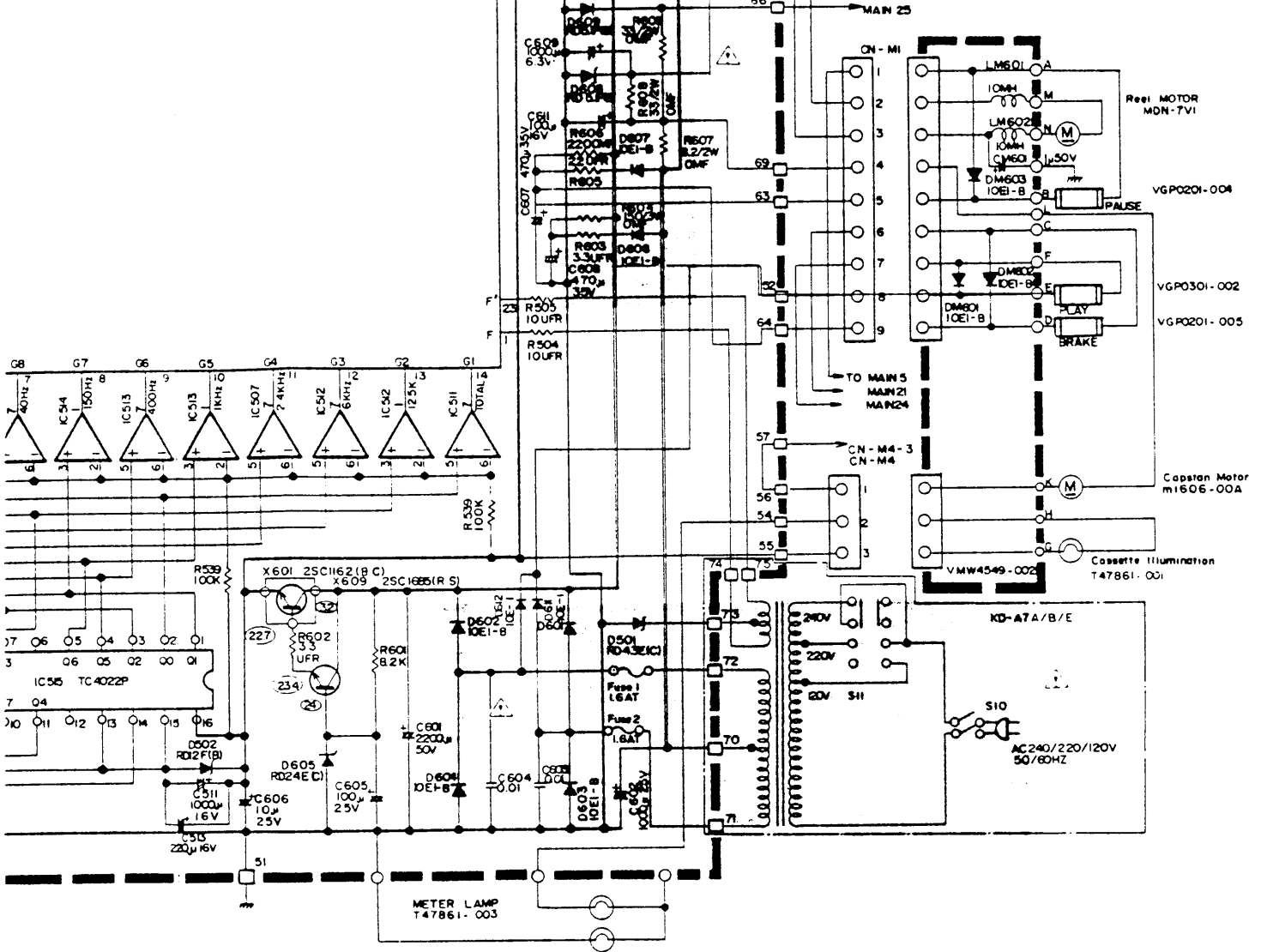

- X601
- X602
- X603
- X604
- X605
- X606
- X607
- X608
- X609

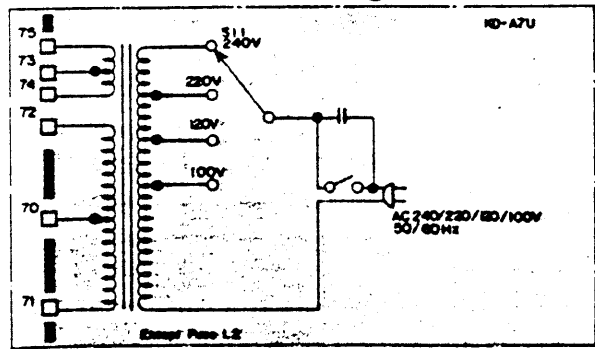
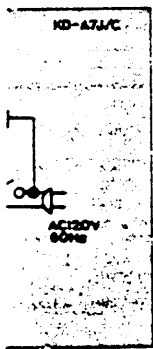

- Diode -

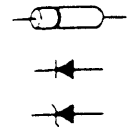

- Transistor -

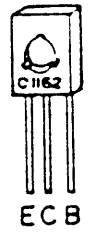
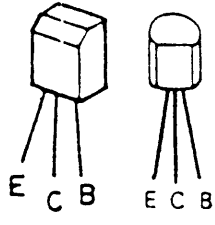

capacitor
modified one.

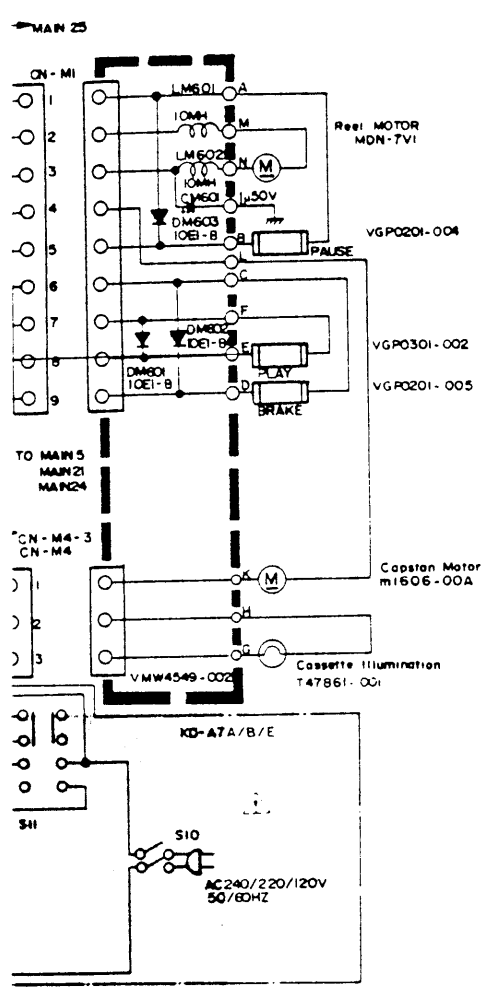

X602	STOP & REW PLAY FF	0 5.8 8.7	12.8	STOP & REW PLAY FF	0 8.4 9.3
X603	FF PLAY & PAUSE Other	8.6 5.6 0	12.0	FF PLAY & PAUSE Other	9.2 6.3 0
X604			REW 8.5 Other 0	FF, PLAY Other 0	0.7 0
X605			FF 8.6 PLAY or PAUSE 5.6 Other 0	REW Other 0	0.75 0
X606			0	0	0
X607			FF 9.2 PLAY 6.3 Other 0	REW, STOP or PAUSE Other 0	0.7 0
X608			FF 4.5 Other 0	PLAY or PAUSE Other 0	0.6 0
X609		23.4	32.0		24.0

